

SOLARA SB

THERMOFORMING PRESS

up to 160 paper items /min

 Made in FRANCE



«SOLARA SB, high speed disposable paper items production line »

- Thermoforming press SOLARA SB is designed for the production of disposable paperboard items such as plates, trays, bowls and containers.
- Thermoforming press SOLARA SB works from cardboard reels integrating functions of unwinding, scoring and punching, forming, stacking, counting and piling up.
- The design of the thermoforming press SOLARA SB makes easy its use and its maintenance.
- The strong forming force exerted by the press, combined with long time pressure, guarantee high quality thermoforming.

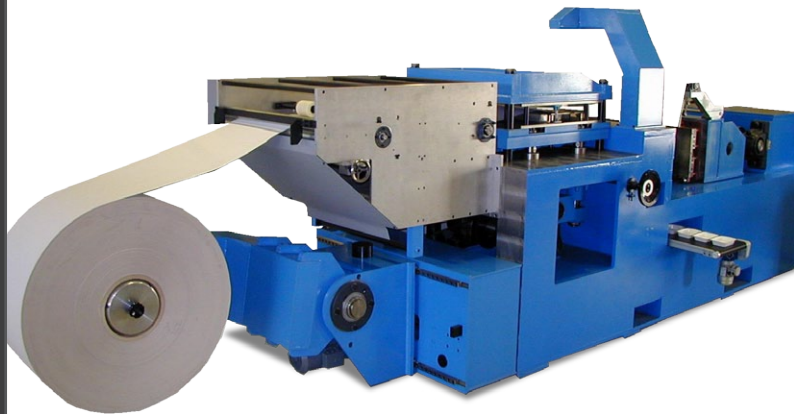

TECHNICAL SPECIFICATIONS

Reel width	up to 800 mm
Maximum diameter of the reel	1600 mm
Number of cavity	from 1 to 5, depending on tray size and reel width
Speed	up to 40 strokes / min, depending on paper quality and item depth i.e. 160 pieces / min for a 4 cavity mold
Weight	20 tons
Maximum depth of the item	65 mm



Rue Roger Thirode - 39800 POLIGNY - France
Tél.: +33 (0)3 84 37 24 12 - Fax: +33 (0)3 84 37 05 57 - gma@gma-france.com

www.gma-france.com



SOLARA SB

THERMOFORMING PRESS

up to 160 paper items /min

 Made in FRANCE

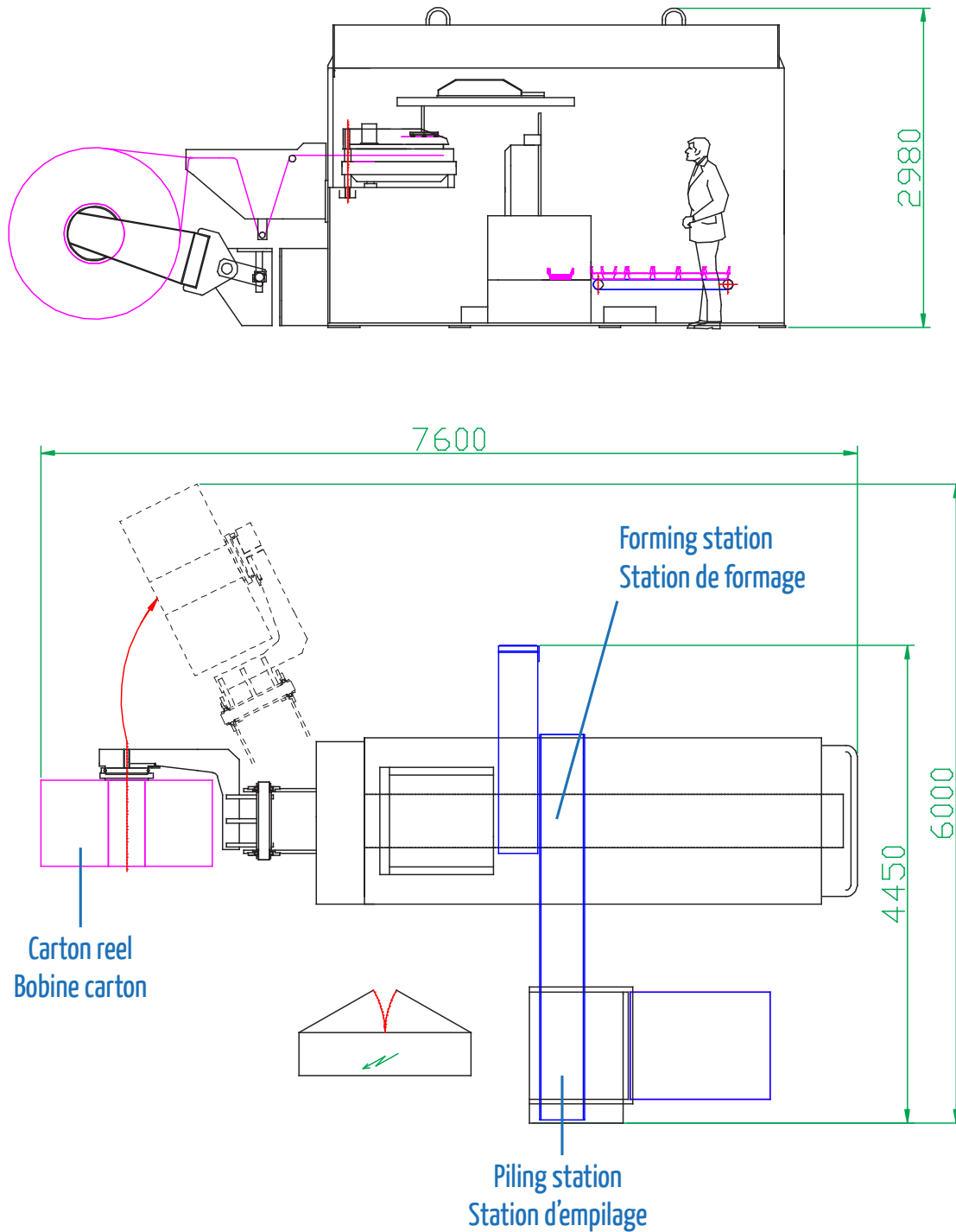

Indicative and non contractual layout.